

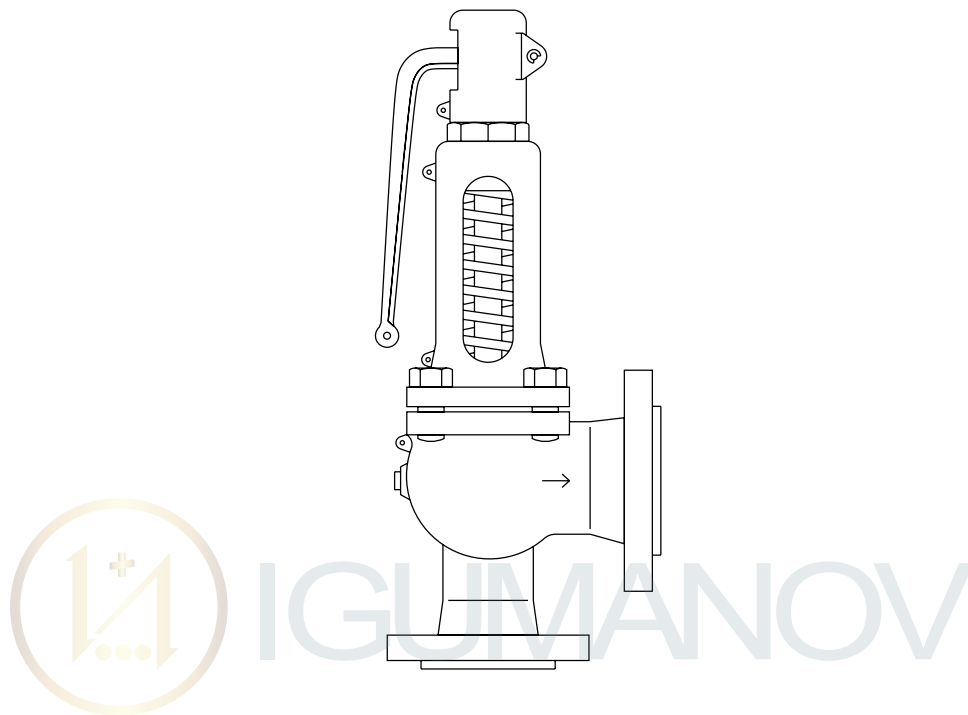

TI-S13-27
 CH Issue 13

SV60 Safety Valve



Description

The SV60 is a range of full lift flanged safety valves suitable for use on steam, inert industrial gas and water services. Please contact Spirax Sarco for suitability of any other media.

Available types

Model and material		Bonnet and cap configuration	
SV604	Carbon steel	Closed bonnet	Open type easing lever
			Sealed cap
SV607	SG iron	Open bonnet	Packed easing lever - DN20 to DN100 only
			Open type easing lever

Applications

The SV60 is suitable for the protection of steam boilers, pipelines, pressure vessels, compressors and receivers and most general process industry applications.

Certification

A manufacturers' Typical Test Report is provided as standard for each valve which will include valve set and hydraulic test pressure. Also available on request is material certification in accordance with EN 10204 3.1.

Standards and approvals

The SV60 carries the CE mark and complies with the requirements of the European Pressure Equipment Directive 97/23/EC falling within Category 4 for Group 2 gases.

Seat tightness to ASME / API Standard 527-1992.

Lloyds Register (LR) type approval - Certificate number 01/00125 (E2).

The SV604 (PN flanged) is approved by the TÜV to AD-Merkblatt A2, AD-Merkblatt A4, TRD 421, Vd TÜV 100, 100/4.

Sizes and end connections

Inlet sizes: DN20, DN25, DN32, DN40, DN50, DN65, DN80, DN100, DN125 and DN150.

Valve type	Inlet connection	Outlet connection
SV607	PN16 (DN65 to DN150 only)	PN16
	PN25	PN16
SV604	PN40	PN16
	ASME 300	ASME 150

Standard PN flanges are to EN 1092 and ASME 300 flanges to EN 1759-1.

Pressure/temperature limits

SV604 PN40 inlet

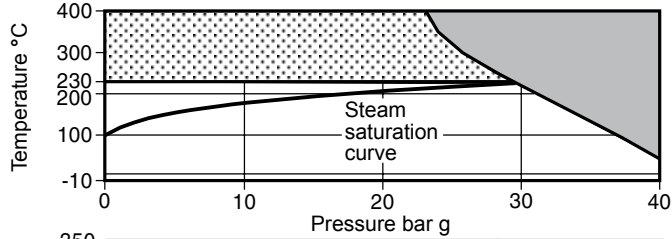

SV607 PN25 inlet

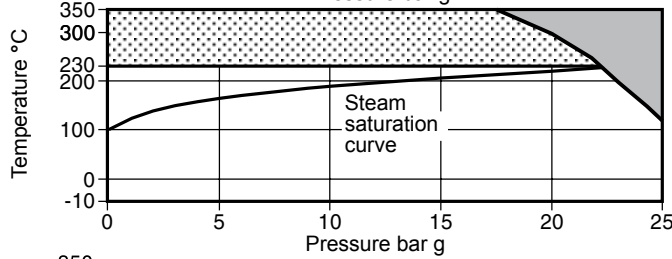

SV607 PN16 inlet

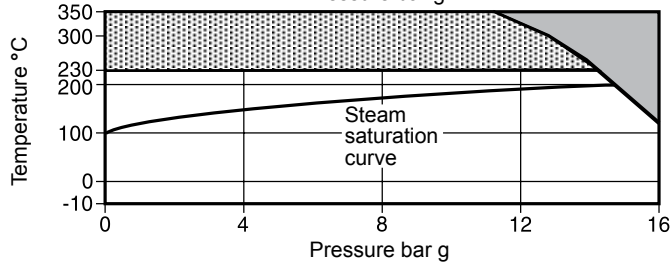

■ This product **must not** be used in this region.

▨ A tungsten alloy spring **must be used** in this region. Consult Spirax Sarco for further information.

Body design conditions		SV604	PN40			
		SV607	PN16 or PN25			
		Size	Saturated steam Air Water			
Set pressure range maximum	SV604	PN40	DN20 x DN32	29 bar g	40 bar g	40 bar g
			DN25 x DN40	29 bar g	40 bar g	40 bar g
			DN32 x DN50	29 bar g	40 bar g	40 bar g
			DN40 x DN65	29 bar g	40 bar g	40 bar g
			DN50 x DN80	29 bar g	40 bar g	40 bar g
	SV607	PN25	DN65 x DN100	29 bar g	32 bar g	32 bar g
			DN80 x DN125	29 bar g	32 bar g	32 bar g
			DN100 x DN150	25 bar g	25 bar g	25 bar g
			DN125 x DN200	20 bar g	20 bar g	20 bar g
			DN150 x DN250	16 bar g	16 bar g	16 bar g
		PN16	DN65 x DN100	14.6 bar g	16 bar g	16 bar g
			DN80 x DN125	14.6 bar g	16 bar g	16 bar g
			DN100 x DN150	14.6 bar g	16 bar g	16 bar g
			DN125 x DN200	14.6 bar g	16 bar g	16 bar g
			DN150 x DN250	14.6 bar g	16 bar g	16 bar g
Set pressure range minimum	SV604 and SV607		0.2 bar g			
Temperature	Maximum	SV604	400°C			
	Minimum	SV607	350°C			
Performance data	Overpressure	SV604 and SV607	-10°C			
		Steam	5%			
	Blowdown limit	Liquids and gas	10%			
		Steam and gas	10%			
	Backpressure limit	Liquids	20%			
Designed for a maximum inlet cold hydraulic test pressure of:	SV604	60 bar g				
	SV607	PN25	38 bar g			
	SV607	PN16	24 bar g			

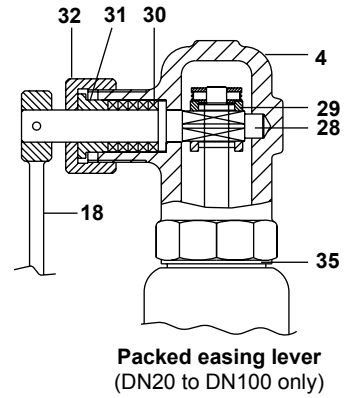
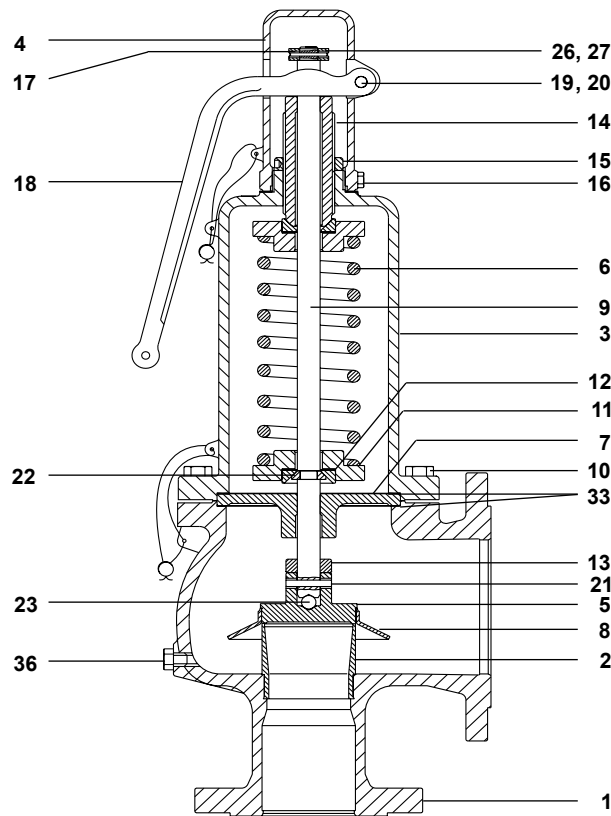
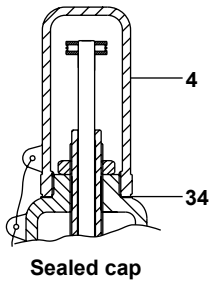

Materials

No.	Part	Material	SV607 / SV604
1	Body	SG iron / carbon steel	GJS-400-18LT / 1.0619 + N
2	Seat	Stainless steel	DN20-DN100 1.4057 or for DN125-DN150 ANC2
3	Bonnet	SG iron / carbon steel	GJS-400-18LT / 1.0619 + N
4	Cap	SG iron	GJS-400-15
5	Disc	Stainless steel, hardened 47-52 HRC (Hardened Rockwell 'C' Scale)	DN20-DN100 1.4021 or for DN125-DN150 CA15
6	Spring	Standard For temperatures above 230°C	Chrome-vanadium alloy steel Tungsten alloy steel
7	Guide plate	SG iron	GJS-400-15
8	Skirt	Stainless steel	DN20-DN100 1.4301 or for DN125-DN150 1.4308
9	Stem	Stainless steel	1.4021
10	Body bolts	Steel	CK35
* 11	Spring plate	Carbon steel	C45E
* 12	Bearing ring (DN80 to DN150 only)	Stainless steel	1.4021
13	Spacer	Stainless steel	1.4021
14	Adjustment screw	Stainless steel	1.4021
15	Lock-nut	Zinc plated carbon steel	
16	Screw	Zinc plated steel	
17	Collar	Zinc plated carbon steel	
18	Lever	SG iron	GJS-400-15
19	Cross pin	Zinc plated carbon steel	
20	Circlip	Spring steel	
21	Disc pin	Spring steel	DIN 7343, A304
22	Collets	Stainless steel	1.4021
23	Stem ball	Stainless steel	
26	Collar pin	Zinc plated carbon steel	
27	Collar circlip	Spring stainless steel	
28	Packed lever spindle	Stainless steel	ASTM A276 431
29	Lifting fork	Carbon steel	
30	Gland packing	Graphite	
31	Gland	Stainless steel	ASTM A276 304
32	Gland nut	Carbon steel	
33	Guide plate gaskets (2 off)	Reinforced exfoliated graphite	
34	Sealed cap gasket	Universal SA	
35	Packed lever cap gasket	Universal SA	
36	Body drain plug ½ BSP	Steel	

* **Note:** The spring plate (11) and bearing ring design (12) varies according to the valve size and set pressure.

Table 1 - SV60 flow capacity for dry saturated steam in kilogrammes per hour (kg/h)
(calculated at 10% overpressure. In accordance with EN ISO 4126)

Valve size DN in/out	20/32	25/40	32/50	40/65	50/80	65/100	80/125	100/150	125/200	150/250
Flow area (mm ²)	230	445	740	1140	1979	2734	4185	6504	8659	12272

Set pressure (bar g)	Dry saturated steam, kg/h									
	0.5	129	269	401	525	875	1 357	1 889	3 053	4 299
1.0	192	403	608	812	1 315	2 014	2 831	4 635	6 380	9 190
1.5	254	538	816	1 102	1 764	2 726	3 793	6 190	8 502	12 235
2.0	312	661	1 005	1 363	2 187	3 367	4 775	7 775	10 665	15 337
2.5	369	789	1 187	1 636	2 631	3 981	5 652	9 162	12 791	18 388
3.0	427	911	1 354	1 867	3 002	4 609	6 551	10 651	14 805	21 278
3.5	485	1 023	1 521	2 097	3 372	5 251	7 471	12 139	16 864	24 233
4.0	538	1 148	1 688	2 326	3 801	5 825	8 289	13 662	18 709	26 883
4.5	591	1 261	1 854	2 555	4 175	6 398	9 104	15 006	20 549	29 527
5.0	644	1 374	2 019	2 783	4 548	6 970	9 917	16 347	22 385	32 165
5.5	697	1 487	2 185	3 011	4 920	7 540	10 729	17 685	24 217	34 798
6.0	750	1 599	2 350	3 239	5 291	8 110	11 539	19 021	26 046	37 427
6.5	802	1 711	2 514	3 466	5 662	8 678	12 349	20 354	27 873	40 052
7.0	855	1 823	2 679	3 693	6 033	9 246	13 157	21 687	29 697	42 673
7.5	907	1 935	2 843	3 919	6 403	9 814	13 964	23 017	31 519	45 291
8.0	959	2 047	3 007	4 145	6 773	10 380	14 771	24 346	33 339	47 907
8.5	1 012	2 158	3 172	4 372	7 143	10 947	15 577	25 675	35 159	50 521
9.0	1 064	2 270	3 336	4 598	7 512	11 513	16 382	27 003	36 976	53 133
9.5	1 116	2 381	3 499	4 824	7 881	12 078	17 187	28 329	38 793	55 743
10.0	1 169	2 493	3 663	5 049	8 250	12 644	17 991	29 655	40 608	58 352
11.0	1 273	2 715	3 991	5 501	8 987	13 774	19 599	32 305	44 237	63 566
12.0	1 377	2 938	4 318	5 952	9 724	14 903	21 206	34 955	47 866	68 780
13.0	1 482	3 161	4 645	6 402	10 460	16 032	22 812	37 601	51 490	73 989
14.0	1 586	3 383	4 972	6 853	11 197	17 161	24 419	40 250	55 117	79 199
15.0	1 690	3 606	5 299	7 304	11 934	18 290	26 025	42 898	58 743	84 410
16.0	1 795	3 829	5 626	7 755	12 671	19 420	27 633	45 547	62 371	89 623
17.0	1 899	4 051	5 954	8 206	13 408	20 549	29 240	48 196	65 999	-
18.0	2 004	4 274	6 281	8 658	14 146	21 680	30 849	50 847	69 630	-
19.0	2 108	4 497	6 609	9 110	14 884	22 812	32 460	53 504	73 267	-
20.0	2 213	4 721	6 937	9 562	15 623	23 944	34 070	56 158	76 902	-
21.0	2 318	4 944	7 266	10 015	16 363	25 078	35 684	58 818	-	-
22.0	2 423	5 168	7 594	10 468	17 103	26 212	37 298	61 479	-	-
23.0	2 528	5 392	7 924	10 922	17 844	27 348	38 915	64 144	-	-
24.0	2 633	5 616	8 253	11 376	18 587	28 487	40 535	66 814	-	-
25.0	2 738	5 841	8 584	11 831	19 331	29 626	42 156	69 487	-	-
26.0	2 844	6 065	8 914	12 286	20 074	30 766	43 777	-	-	-
27.0	2 949	6 291	9 245	12 743	20 820	31 909	45 404	-	-	-
28.0	3 058	6 524	9 587	13 214	21 590	33 089	47 083	-	-	-
29.0	3 163	6 748	9 917	13 669	22 333	34 228	48 704	-	-	-

Table 2 - SV60 flow capacity for air - normal m³/h at 0°C and 1013 mbar
(calculated in accordance with AD-MERKBLATT A2 and TRD 421)

Valve size DN in/out	20/32	25/40	32/50	40/65	50/80	65/100	80/125	100/150	125/200	150/250
Orifice (mm)	17.0	23.8	30.6	38.0	50.1	59.0	73.0	91.0	105	125
Flow area (mm ²)	230	445	740	1 140	1 979	2 734	4 185	6 504	8 659	12 272
α_w (P > 4 bar)	0.78	0.86	0.76	0.68	0.64	0.71	0.66	0.70	0.72	0.73

Set pressure (bar g)	Flow capacity for air m ³ /h									
0.5	145	304	456	472	996	1 521	2 115	3 466	4 809	6 955
1.0	227	480	728	973	1 578	2 419	3 383	5 514	7 621	10 975
1.5	303	643	975	1 323	2 125	3 251	4 572	7 434	10 267	14 753
2.0	377	802	1 211	1 657	2 657	4 062	5 742	9 328	12 885	18 509
2.5	450	956	1 438	1 978	3 171	4 853	6 892	11 195	15 467	22 232
3.0	522	1 107	1 656	2 289	3 672	5 627	8 026	13 015	18 018	25 924
3.5	593	1 255	1 868	2 591	4 161	6 388	9 146	14 837	20 542	29 590
4.0	660	1 411	2 074	2 858	4 670	7 157	10 184	16 785	22 986	33 029
4.5	728	1 554	2 285	3 149	5 145	7 884	11 219	18 491	25 321	36 385
5.0	795	1 697	2 496	3 439	5 619	8 611	12 254	20 196	27 657	39 741
5.5	862	1 841	2 706	3 730	6 094	9 338	13 289	21 902	29 992	43 097
6.0	929	1 984	2 917	4 020	6 568	10 065	14 324	23 607	32 328	46 452
6.5	996	2 127	3 128	4 310	7 043	10 793	15 359	25 313	34 663	49 808
7.0	1 063	2 271	3 339	4 601	7 517	11 520	16 393	27 018	36 999	53 164
7.5	1 130	2 414	3 549	4 891	7 992	12 247	17 428	28 724	39 334	56 520
8.0	1 197	2 557	3 760	5 182	8 466	12 974	18 463	30 429	41 670	59 876
8.5	1 264	2 701	3 971	5 472	8 941	13 701	19 498	32 135	44 005	63 232
9.0	1 332	2 844	4 182	5 763	9 415	14 428	20 533	33 840	46 341	66 588
9.5	1 399	2 987	4 392	6 053	9 890	15 156	21 567	35 546	48 677	69 944
10.0	1 466	3 131	4 603	6 343	10 365	15 883	22 602	37 251	51 012	73 300
11.0	1 600	3 417	5 025	6 924	11 314	17 337	24 672	40 662	55 683	80 012
12.0	1 734	3 704	5 446	7 505	12 263	18 791	26 741	44 073	60 354	86 724
13.0	1 868	3 990	5 868	8 086	13 212	20 246	28 811	47 484	65 025	93 436
14.0	2 003	4 277	6 289	8 667	14 161	21 700	30 881	50 895	69 696	100 148
15.0	2 137	4 564	6 711	9 248	15 110	23 154	32 950	54 306	74 367	106 860
16.0	2 271	4 850	7 132	9 828	16 059	24 609	35 020	57 717	79 038	113 572
17.0	2 405	5 137	7 554	10 409	17 008	26 063	37 090	61 129	83 709	-
18.0	2 539	5 424	7 975	10 990	17 957	27 517	39 159	64 540	88 380	-
19.0	2 674	5 710	8 397	11 571	18 906	28 972	41 229	67 951	93 051	-
20.0	2 808	5 997	8 818	12 152	19 855	30 426	43 299	71 362	97 723	-
21.0	2 942	6 284	9 240	12 733	20 804	31 880	45 368	74 773	-	-
22.0	3 076	6 570	9 661	13 314	21 753	33 335	47 438	78 184	-	-
23.0	3 210	6 857	10 083	13 894	22 702	34 789	49 507	81 595	-	-
24.0	3 345	7 144	10 504	14 475	23 651	36 243	51 577	85 006	-	-
25.0	3 479	7 430	10 926	15 056	24 600	37 698	53 647	88 417	-	-
26.0	3 613	7 717	11 347	15 637	25 549	39 152	55 716	-	-	-
27.0	3 747	8 004	11 769	16 218	26 498	40 606	57 786	-	-	-
28.0	3 882	8 290	12 190	16 799	27 447	42 061	59 856	-	-	-
29.0	4 016	8 577	12 612	17 379	28 397	43 515	61 925	-	-	-
30.0	4 150	8 864	13 033	17 960	29 346	44 969	63 995	-	-	-
31.0	4 284	9 150	13 455	18 541	30 295	46 424	66 064	-	-	-
32.0	4 418	9 437	13 876	19 122	31 244	47 878	68 134	-	-	-
33.0	4 553	9 724	14 298	19 703	31 907	-	-	-	-	-
34.0	4 687	10 010	14 719	20 284	32 865	-	-	-	-	-
35.0	4 821	10 297	15 141	20 865	33 809	-	-	-	-	-
36.0	4 955	10 583	15 562	21 445	34 749	-	-	-	-	-
37.0	5 089	10 870	15 984	22 026	35 690	-	-	-	-	-
38.0	5 224	11 157	16 405	22 607	36 631	-	-	-	-	-
39.0	5 358	11 443	16 826	23 188	37 572	-	-	-	-	-
40.0	5 492	11 730	17 248	23 769	38 514	-	-	-	-	-

Table 3 - SV60 flow capacity for water in tonnes/h at 25% overpressure
(calculated in accordance with AD-MERKBLATT A2 and TRD 421)

Valve size DN in/out	20/32	25/40	32/50	40/65	50/80	65/100	80/125	100/150	125/200	150/250
Orifice (mm)	17.0	23.8	30.6	38.0	50.1	59.0	73.0	91.0	105	125
Flow area (mm ²)	230	445	740	1140	1979	2734	4185	6504	8659	12272
α_w	0.5	0.5	0.5	0.5	0.5	0.5	0.5	0.5	0.5	0.5

Set pressure (bar g)	Flow capacity for water tonnes/h									
	20/32	25/40	32/50	40/65	50/80	65/100	80/125	100/150	125/200	150/250
0.5	4.6	8.9	14.9	22.9	39.8	55.0	84.1	130.8	174.1	246.7
1.0	6.5	12.6	21.0	32.4	56.3	77.7	119.0	184.9	246.2	348.9
2.0	9.2	17.9	29.8	45.8	79.6	109.9	168.3	261.5	348.2	493.5
3.0	11.3	21.9	36.5	56.1	97.5	134.6	206.1	320.3	426.4	604.4
4.0	13.1	25.3	42.1	64.8	112.6	155.5	238.0	369.9	492.4	697.9
5.0	14.6	28.3	47.1	72.5	125.8	173.8	266.1	413.5	550.5	780.2
6.0	16.0	31.0	51.6	79.4	137.8	190.4	291.5	453.0	603.1	854.7
7.0	17.3	33.5	55.7	85.8	148.9	205.7	314.9	489.3	651.4	923.2
8.0	18.5	35.8	59.5	91.7	159.2	219.9	336.6	523.1	696.4	986.9
9.0	19.6	37.9	63.1	97.2	168.8	233.2	357.0	554.8	738.6	1046.8
10.0	20.6	40.0	66.6	102.5	178.0	245.8	376.3	584.8	778.6	1103.4
11.0	21.7	42.0	69.8	107.5	186.6	257.8	394.7	613.3	816.6	1157.3
12.0	22.6	43.8	72.9	112.3	194.9	269.3	412.2	640.6	852.9	1208.7
13.0	23.5	45.6	75.9	116.9	202.9	280.3	429.1	666.8	887.7	1258.1
14.0	24.4	47.3	78.8	121.3	210.6	290.9	445.3	691.9	921.2	1305.6
15.0	25.3	49.0	81.5	125.5	218.0	301.1	460.9	716.2	953.5	1351.4
16.0	26.1	50.6	84.2	129.7	225.1	310.9	476.0	739.7	984.8	1395.7
17.0	26.9	52.2	86.8	133.7	232.0	320.5	490.7	762.5	1015.1	-
18.0	27.7	53.7	89.3	137.5	238.8	329.8	504.9	784.6	1044.6	-
19.0	28.5	55.1	91.7	141.3	245.3	338.8	518.7	806.1	1073.2	-
20.0	29.2	56.6	94.1	145.0	251.7	347.6	532.2	827.0	1101.1	-
21.0	29.9	58.0	96.5	148.6	257.9	356.2	545.3	847.4	-	-
22.0	30.6	59.3	98.7	152.0	264.0	364.6	558.2	867.4	-	-
23.0	31.3	60.7	100.9	155.5	269.9	372.8	570.7	886.9	-	-
24.0	32.0	62.0	103.1	158.8	275.7	380.8	583.0	906.0	-	-
25.0	32.6	63.2	105.2	162.1	281.4	388.7	595.0	940.0	-	-
26.0	33.3	64.5	107.3	165.3	287.0	396.4	606.8	-	-	-
27.0	33.9	65.7	109.4	168.4	292.4	403.9	618.4	-	-	-
28.0	34.6	66.9	111.4	171.5	297.8	411.3	629.7	-	-	-
29.0	35.2	68.1	113.3	174.6	303.1	418.6	640.9	-	-	-
30.0	35.8	69.3	115.3	177.6	308.2	425.8	651.8	-	-	-
31.0	36.4	70.4	117.2	180.5	313.3	432.8	662.6	-	-	-
32.0	36.9	71.6	119.1	183.4	318.3	439.7	673.2	-	-	-
33.0	37.5	72.7	120.9	186.2	323.3	-	-	-	-	-
34.0	38.1	73.8	122.7	189.0	328.1	-	-	-	-	-
35.0	38.6	74.8	124.5	191.8	332.9	-	-	-	-	-
36.0	39.2	75.9	126.3	194.5	337.7	-	-	-	-	-
37.0	39.7	76.9	128.0	197.2	342.3	-	-	-	-	-
38.0	40.3	78.0	129.7	199.8	346.9	-	-	-	-	-
39.0	40.8	79.0	131.4	202.4	351.4	-	-	-	-	-
40.0	41.3	80.0	133.1	205.0	355.9	-	-	-	-	-

Table 4 α_w /Kdr values for SV60 safety valves

Size	Set pressure (bar g)								
	0.2 - 0.49	0.5 - 0.99	1.0 - 1.49	1.5 - 1.99	2.0 - 2.49	2.5 - 2.99	3.0 - 3.49	3.5 - 3.99	Above 4.0
DN20 x DN32	0.56	0.62	0.69	0.73	0.75	0.76	0.77	0.78	0.78
DN25 x DN40	0.62	0.67	0.75	0.80	0.82	0.84	0.85	0.85	0.86
DN32 x DN50	0.56	0.60	0.68	0.73	0.75	0.76	0.76	0.76	0.76
DN40 x DN65	0.45	0.51	0.59	0.64	0.66	0.68	0.68	0.68	0.68
DN50 x DN80	0.47	0.49	0.55	0.59	0.61	0.63	0.63	0.63	0.64
DN65 x DN100	0.50	0.55	0.61	0.66	0.68	0.69	0.70	0.71	0.71
DN80 x DN125	0.45	0.50	0.56	0.60	0.63	0.64	0.65	0.66	0.66
DN100 x DN150	0.48	0.52	0.59	0.63	0.66	0.67	0.68	0.69	0.70
DN125 x DN200	0.50	0.55	0.61	0.65	0.68	0.70	0.71	0.72	0.72
DN150 x DN250	0.51	0.56	0.62	0.66	0.69	0.71	0.72	0.73	0.73

Sizing and selection

Refer to: - <http://www.spiraxsarco.com/prs/product-sizing.asp>

Dimensions/weights (approximate) in mm and kg

Size Inlet / Outlet	Dimensions			Flow Ø D	Weight	
	A	B	C		SV604	SV607
DN20 - DN32	85	95	385	17.0	10.5	10.5
DN25 - DN40	100	105	435	23.8	12.5	11.5
DN32 - DN50	110	115	450	30.6	16.0	15.0
DN40 - DN65	115	140	520	38.0	18.0	18.0
DN50 - DN80	120	150	535	50.1	20.0	22.0
DN65 - DN100	140	170	710	59.0	40.0	38.0
DN80 - DN125	160	195	790	73.0	56.0	53.0
DN100 - DN150	180	220	835	91.0	77.0	75.0
DN125 - DN200	200	250	1042	105.0	120.0	115.0
DN150 - DN250	225	285	1165	125.0	190.0	180.0

Safety information, installation and maintenance

For full details see the Installation and Maintenance Instructions (IM-P137-01) supplied with the product.

Installation note:

The safety valve should always be fitted with the centre line of the spring housing vertically above the valve. Open bonnet valves are recommended for all steam boiler applications and for valves fitted with Tungsten alloy springs.

SV60 safety valve selection guide:

Model type	SV60	SV60
Body material	4 = Carbon steel 7 = SG iron	4
Configuration	A = Closed bonnet / easing lever B = Closed bonnet / sealed cap C = Closed bonnet / packed lever (DN20 to DN100 only) D = Open bonnet / easing lever	A
Seal material	S = Stainless steel with chrome-vanadium alloy steel spring T = Stainless steel with tungsten alloy steel spring	S
Size	DN20 to DN150	DN20
Inlet connection	PN16 (DN65 to DN150 only), PN25, PN40 or ASME (ANSI) 300	PN40

Selection example **SV60 4 A S DN20 PN40**

How to order example

1 off Spirax Sarco SV604AS, DN20 flanged PN40 safety valve with a set pressure of 6 bar g.

